

# HYBRID BUCKET

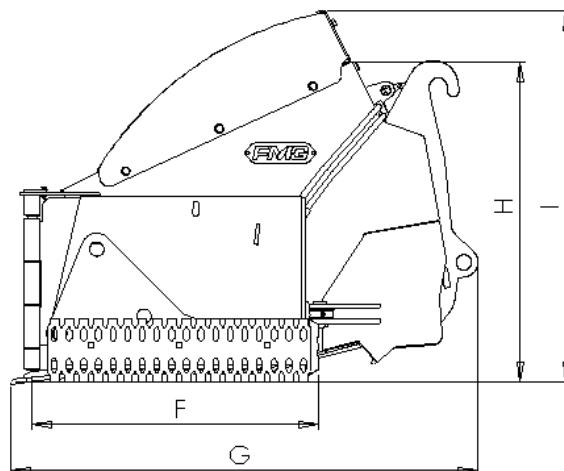
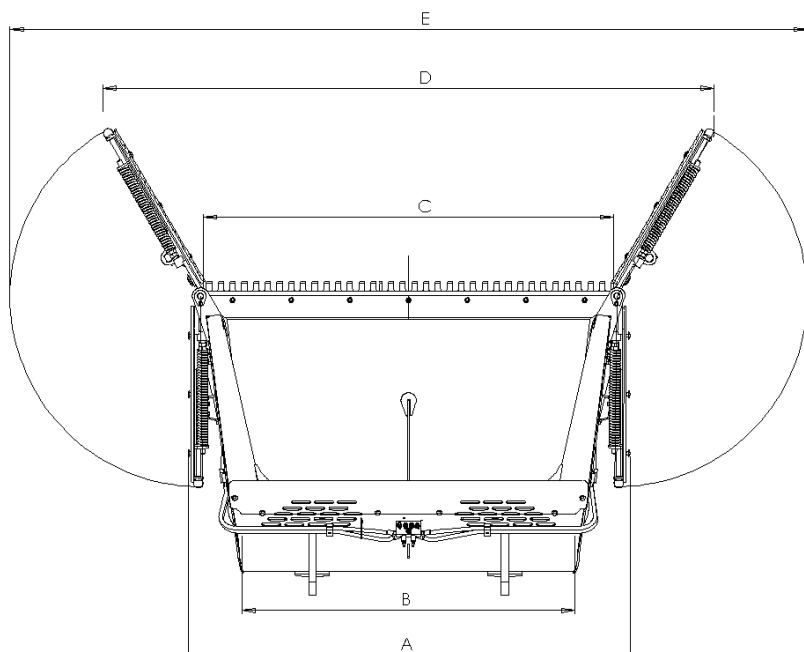

Model		CBW180/10	CBW200/12	CBW230/20	CBW230/25	CBW260/20	CBW260/30	CBW280/45	CBW300/55
Width (cm)	A	180	200	230	230	260	260	280	300
Ice-removing blade (cm)	B	131	152	178	173	209	201	214	240
Cutting edge (cm)	C	166	186	214	214	244	244	260	275
Working width when wings turned forward (cm)	D	248	258	305	318	343	349	380	400
Max. working width (cm)	E	298	318	377	414	408	444	487	507
Wing width (cm)	F	65	65	81	100	81	100	110	110
Bucket depth (cm)	G	129	125	143	163	143	164	184	184
Height without extension walls (cm)	H	89	87	99	111	99	110	128	128
Height with extension walls (cm)	I	109	106	119	129	118	128	153	153
Capacity (l)		1000	1200	2000	2500	2000	3000	4500	5500
Weight (kg) (varies by optional equipment)		445	560	815	1115	895	1120	1450	1600
Adapters with screws		X	X	X	-	X	-	-	-