



A Brand
for Professionals

FMIG

HD-SCRAPER



RAP300HD



HD-SCRAPER

When you demand more

Already legendary FMG scraper is a popular work equipment for removing ice and for levelling roads. The new HD-Scraper from FMG completes the scraper collection for tractors over 200hp/10000kg, for hard use.

FMG HD-Scraper is designed to respond for the durability and more flexible operating features required by more powerful and heavier tractors. HD-Scraper has the same features as basic scraper, but it also has something new as hydraulic extension wings as an option. Everything is designed so that tractor's loads on the structures of the scraper has considered and the whole scraper is even more robust.

The new FMG HD-Scraper is equipped with removable hydraulic pressure cylinder that makes the coupling of the HD-Scraper easier. The 3m wide basic blade already enables a lot, but the optional hydraulic extensions give you additional working width and new possibilities for work. As standard equipment you get the revolving, (290mm wide) support wheels, stinger blade, pressure release sockets for hoses with collector, toolbox with reserve pins and tools for changing stinger studs, and accumulators. As an option, it is possible to get the hydraulically operated support wheels.



WHY HD-SCRAPER?

- **robust construction for big tractors**
- **wide revolving support wheels**
- **new removable hydraulic pressure cylinder**
- **hydraulic extensions as option**
- **several blade options**
- **toolbox with spare pins and tools for changing stinger studs**
- **pressure release sockets (with collector) for hoses storage**
- **2 years warranty**



Turning angle + - 27 degrees

Due to the large turning angle to both side, HD-scraper enables to use for road maintenance in summer and winter.



More working width with hydraulically operated extensions (option)

You can easily and quickly change the working width from 3 m to 3,9 m.



Hydraulically operated support wheels (option)

By adjusting the height of the support wheel, the working height can be adjusted accurately.

ROBUST CONSTRUCTION

Designed for tractors over 200hp/10000kg.
HD-scraper weight is 1200 kg without
extensions and 1600 kg with extensions.

**REMOVABLE HYDRAULIC
PRESSURE CYLINDER**

The connection of HD-scraper is
easier than ever.

**PRESSURE RELEASE SOCKETS (WITH
COLLECTOR) FOR HOSES STORAGE**

**HYDRAULICALLY OPERATED
SUPPORT WHEELS (OPTION)**

**HYDRAULICALLY
OPERATED EXTENSIONS
(OPTION)**

Extensions give additionally
90 cm of working width.

WIDE SUPPORT WHEELS

290 mm wide revolving
support wheels. The print
of the support wheels in
the pictures may differ from
the print of the delivered wheels.

TOOLBOX

Spare pins and tools for changing
stinger stubs are included in the
toolbox as standard.

STINGER BLADES (OPTION)

Stinger blades are perfectly suitable
for road maintenance in summer
and ice remove in winter.

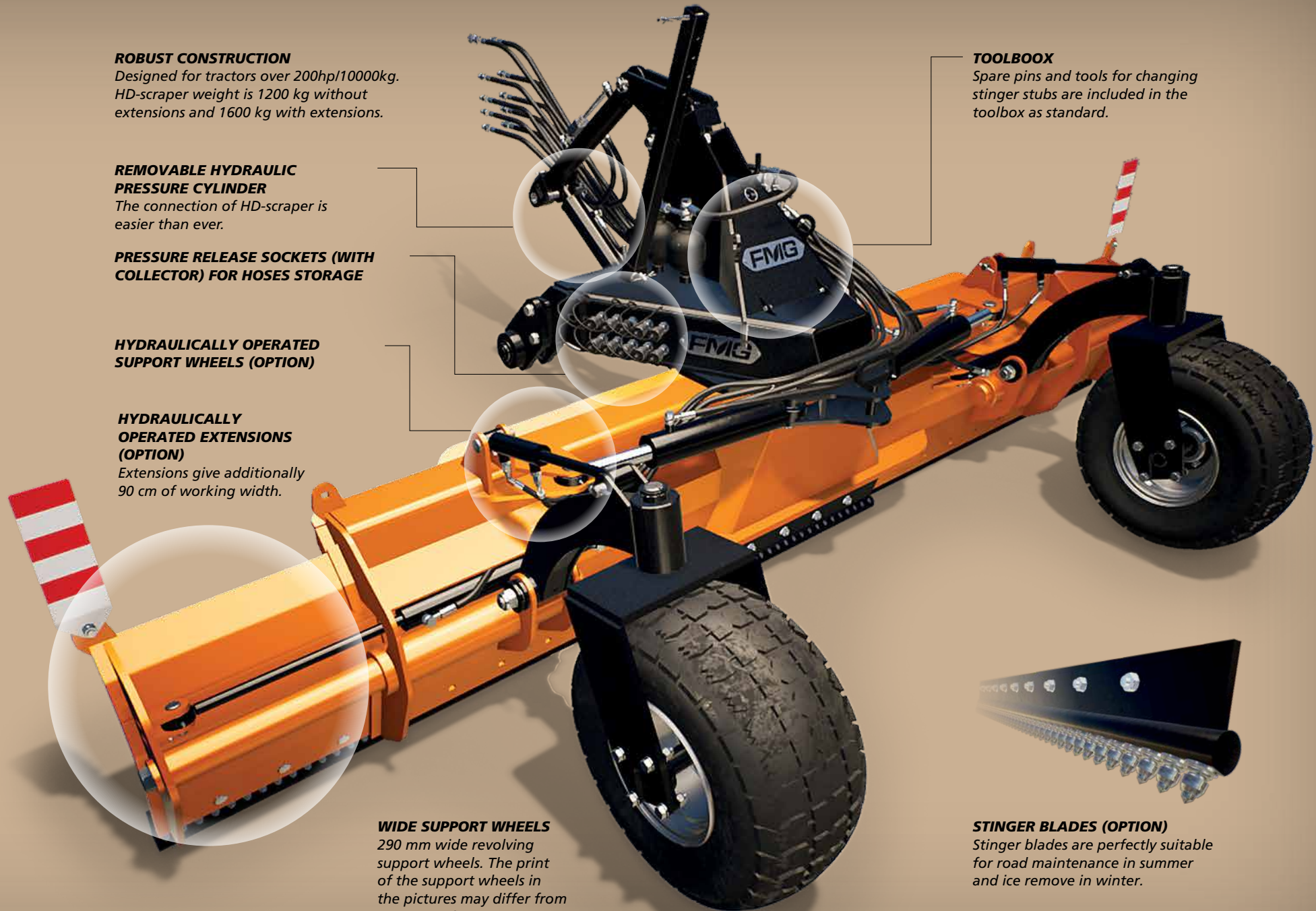



EQUIPMENT AND TECHNICAL INFORMATION

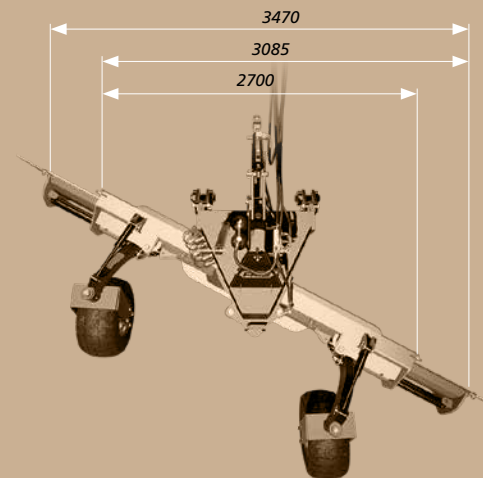
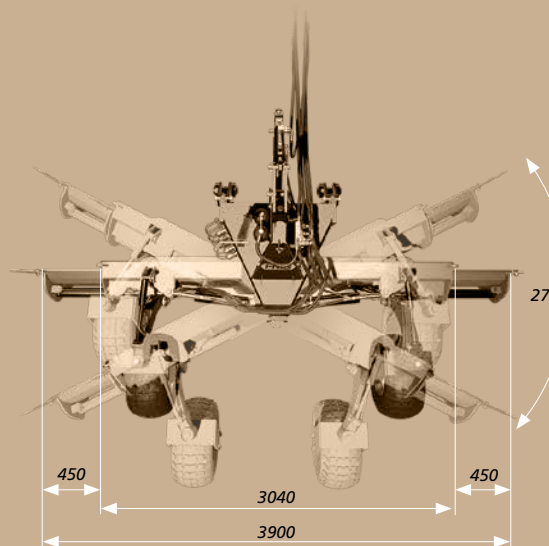
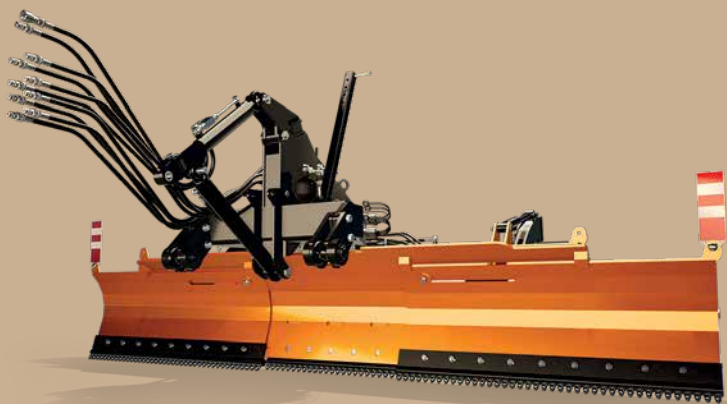

STANDARD EQUIPMENT

- even blade 3m
- support wheels (revolving)
- hydraulic top link
- hydraulic pressure cylinder
- hydraulic turning (+/-27 degrees)
- toolbox
- tools for changing stinger stubs

OPTIONAL EQUIPMENT

- hydraulic extensions (left and right)
- hydraulic support wheels (right orland left)
- perforated blade
- stinger blade
- toothed hard metal cutting edge
- electric valve 6/2 with external coupling and electric control (inc. control box and Hella Din power cord for control)

Model	Width, mm	Height, mm	Working width, mm	Ext. wing, mm	Turning angle, °	Weight, kg
RAP300HD - no extension wings	3040	640	2700 - 3000	-	+/- 27	1200
RAP300HD - with extension wings	3040	640	2700 - 3900	2 x 450	+/- 27	1600

Contact us

FMG - LLP Farm Machinery Group

Tel. +358 20 1984 020

Email sales@fmg.fi

Web www.fmg.fi