



OPERATORS MANUAL PA300-PA390

ORIGINAL



ORIGINAL

EY-VAATIMUSTENMUKAISUUSVAKUUTUS TUOTTEESTA

LLP Farm Machinery Group Oy vakuuttaa, että markkinoille saatettu kone täyttää direktiivin 2006/42/EY ja standardit SFS-EN ISO 12100 ja SFS-ISO 730:2020.

FÖRSÄKRAN OM ÖVERENSSTÄMMELSE

LLP Farm Machinery Group Oy försäkrar härmed att tillförda maskin uppfyller maskindirektivet 2006/42/EY och standard SFS-EN ISO 12100 och SFS-ISO 730:2020.

CERTIFICATE OF CONFORMITY FOR A PRODUCT

LLP Farm Machinery Group Oy certifies that the following machine, which has been brought into the market, conforms to directives 2006/42/EY and standards SFS-EN ISO 12100 and SFS-ISO 730:2020.

SAMSVARSERKLÆRING FOR MASKIN

LLP Farm Machinery Group Oy bekrefter herved at følgende maskin, som er sendt ut på markedet, er i samsvar med direktivene 2006/42/EF, SFS-EN ISO 12100 og SFS-ISO 730:2020.

Tuote / Produkt / Product / Produkt: _____

Valmistusnumero / Tillverkningsnummer
/ Serial number / Serienummer: _____

Teknisen tiedoston kokoaja / Teknisk
dokumentation samlare / Technical file collector:

Valmistaja / Tillverkare / Manufacturer
/ Produsent: LLP Farm Machinery Group Oy

Osoite / Adress / Address / Adresse: Levytie 4, FIN-74510 Iisalmi

Puhelin / Telefon / Telephone: +358 (0) 201 984 020

Paikka / Ort / Place / Sted: Iisalmi

Aika / Datum / Date / Dato: _____

Allekirjoitus / Underskrift / Signature
/ Signatur:



Nimenselvennys / Namnförtydligande
/ Clarification of signature
/ Tydeliggjøring av signatur:

Jarkko Hyyrönmäki

WARRANTY TERMS

All the products produced by LLP Farm Machinery Group Oy have twenty four (24) months warranty.

During the warranty period all the defects in material and in workmanship will be covered, in practical life FMG will replace defected parts with the new parts. Travelling expenses and freight of parts are not included in warranty.

Warranty will start in the beginning of usage of the product, if nothing else has been agreed.

Warranty is not covering damages due to misuse of product or use in the purposes where it has not been designed, lack of services or product has been modified without the permission of FMG.

Wearing of the normal usage is not covered by the warranty.

Losses in income, costs and loosen working hours caused by the defected part is not covered by the warranty.

Warranty repairs should be done by the FMG service dealer or service dealer appointed by the manufacturer.

In case the defects shown in reclamation is not valid or if case otherwise is not in the warranty area FMG has right to reject from the compensation.

Warranty reclamation should be done in written form by the FMG seller within one (1) month after notifying the defect.

In case of defect procedure is as follows:

- clarify the defect and defected area
- be prepared to deliver defected parts to the manufacturer
- contact FMG seller and make reclamation as follows:
 - type of the product and serial number
 - delivery date of the product (invoicing date)
 - date of the damage
 - description of the damage and pictures
 - description of the working conditions and the type of the base machine

TO THE OPERATOR

The purpose of this manual is to provide support and instructions to butterfly plough users. Manual contains detailed instructions for driving, operating and maintaining the plough. Make sure that your new plough is always handled and maintained in the correct way in order to ensure reliability and economical operation for many years.

We recommend that you read the manual thoroughly. Follow the maintenance and service program carefully and include the daily maintenance in your normal routine. This is both you and your tractor interest.

Maintenance, repairs and adjustments which are not described in this Operator Manual require the use of special tools and exact technical data. In case of that kind need please contact your FMG seller or factory.

Use only genuine FMG spare parts for optimum performance from your tractor and plough. Spares will be sold through the FMG seller.

TABLE OF CONTENTS

1. SAFETY INSTRUCTIONS	6
2. CONSTRUCTION	8
3. TECHNICAL SPECIFICATION	9
4. BUTTERFLY PLOUGH USE	9
4.1. Using plough	9
4.2. Instructions	9
4.3. Butterfly plough use:.....	10
4.4. Pressure adjustment of the hydraulic suspension	12
5. SERVICE	13
5.1. Daily service	13
5.2. Weekly service	13
5.3. Service after 500 working hours.....	13
5.4. Annual service.....	13
5.5. Lubrication	15
5.6. Screws to be tighten.....	16
6. ELECTRIC VALVE AND SIDE LIGHTS CONNECTION	17

1. SAFETY INSTRUCTIONS

This section summarizes the regulations that must always be followed when working with the plough. However, these regulations do not exempt the driver from statutory and other national regulations regarding traffic safety and occupational health and safety. Safety regulations that apply to different types of working sites and existing road traffic laws must always be observed. Tractor safety regulations accepted by the Finnish occupational safety and health administration have already been taken into account in the equipment design. The following section describes general safety precautions that must be observed regarding the use of the plough.



IMPORTANT

Do not use the plough for other purposes than it has been designed. Please read this manual carefully before using the implement.



IMPORTANT

Before driving, make sure that all movements and functions work correctly.



DANGER

When testing different movements of the plough make sure that there is no one close to tractor. Safety distance 5 meters.



IMPORTANT

Advise other users on the use of the implement and ask them to read the manual.



DANGER

Do not operate a faulty implement.



IMPORTANT

Use the rotary beacon while working.



WARNING

Observe the manufacturer's instructions while working.



WARNING

Pay attention to other road users.



IMPORTANT

Always lower the implement and stop the engine before leaving the cab.



IMPORTANT

Never service or clean an implement that is resting on the hydraulics. Use mechanical support. Always stop the engine for maintenance.



WARNING

Do not disconnect, connect or tighten pressurized hydraulic plugs.



WARNING

Do not inhale oil mist if a pressurized component becomes damaged. If oil comes into contact with the eyes, rinse with plenty of water and contact a doctor immediately.



DANGER

Pay attention to the direction of the plough in relation to the tractor. The plough attempts to steer the tractor.

2. CONSTRUCTION

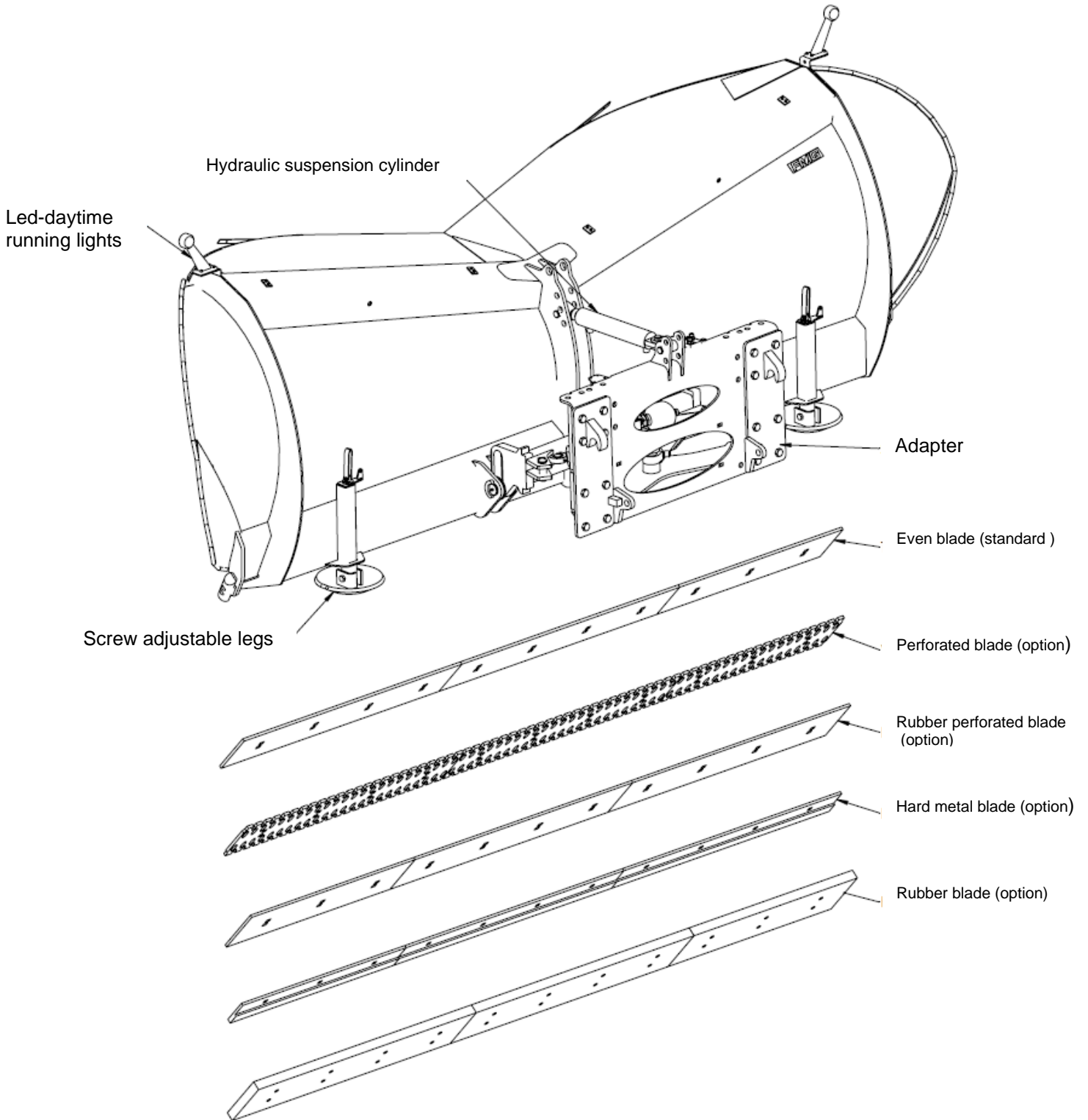

3. TECHNICAL SPECIFICATION

Model	Height (cm)	Width (cm)	Working width (cm)	Wing angle	Weight (kg)
PA300	138	397	220 - 305	41 / 45	895
PA330	145	428	240 - 335	41 / 45	935
PA360	152	460	260 - 365	41 / 45	975
PA390	159	490	285 - 395	41 / 45	1040

Sound level is less than 70 dB (A)

4. BUTTERFLY PLOUGH USE

4.1. *Using plough*

Butterfly plough is especially designed to the light traffic roads. Butterfly plough is beneficial also when cleaning yards and terminals.

4.2. *Instructions*

Before use check that plough is engaged properly to the working machine and all the locking´s are well done.

Test drive working machine and plough combination to ensure that all have been engaged well. If plough is new or it have been modified ensure that air has been eliminated from the system. Air in hydraulic system could cause unexpected movements.

When using areal plough ensure that your sight is clear to the ploughing area and there is not anyone in the dancer zone.

When disengage plough, put shields to the hydraulic hoses.

When disengage plough outside ensure that ground is balanced to help next engage. Wood blocks would be beneficial to balance the area.

If plough will stay longer period without usage, lubricate piston rods with CORRSHIELD VPCI-369 corrosion shield or with storage oil to avoid corrosion.

4.3. **Butterfly plough use:**

Engage plough to the working machine that floating bar is in the mid position and plough is in the balanced position (Picture 2).

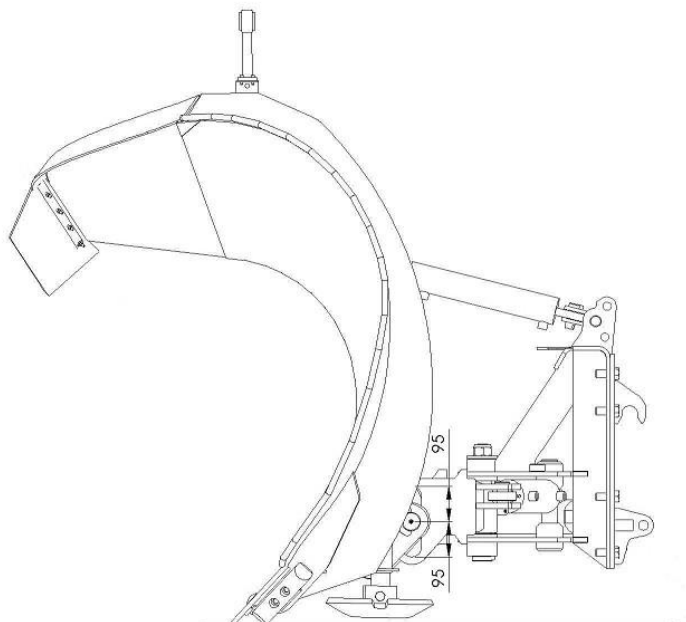

Picture 2. Floating bar in the mid position

In case the adapter is wrong change adapter and ensure that screws are tightened well.

Turn wing to the correct angle to get best possible ploughing result.



IMPORTANT

When plough is new take care that air from hydraulic system will be eliminated by turning cylinders against to the limit stoppers couple of the time.

Adjust support legs in order to blade will get correct height from the surface.

In case of front loader application beam support are recommended.

Working position of plough is correct when frame is in the upright position (Picture 3).

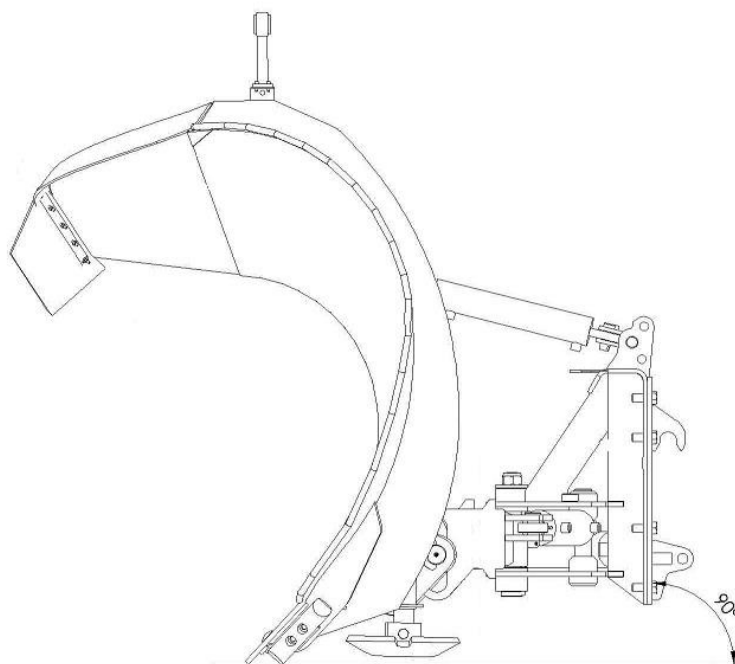

Picture 3. Plough frame in the upright position

In normal working position hydraulic suspension cylinder is in the minimum position. Blade angle is possible to adjust by moving suspension cylinder to another hole (3 different alternative) (Picture 4).

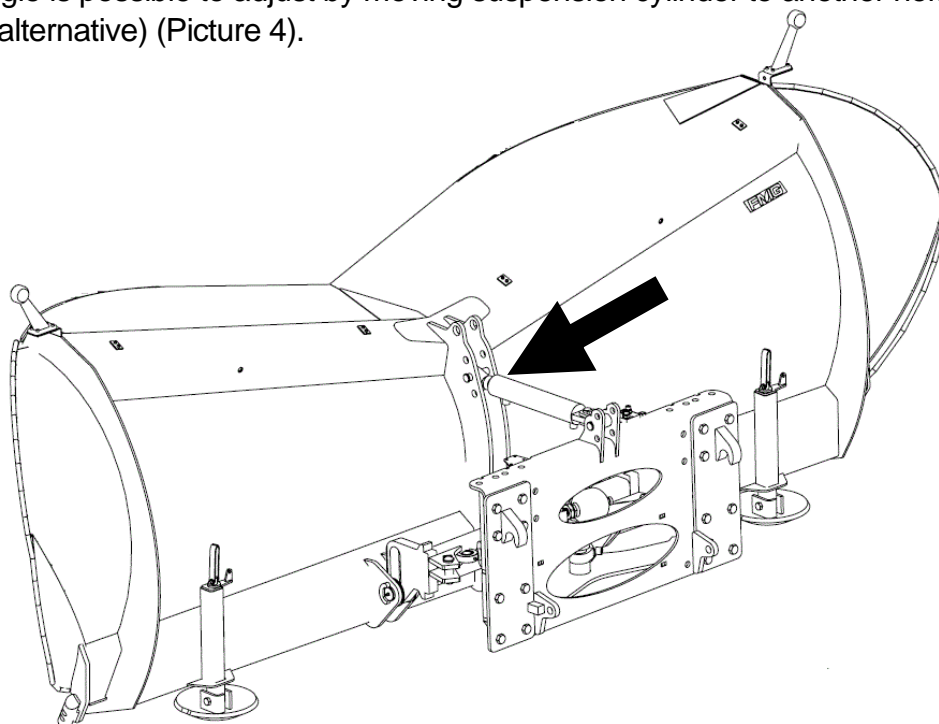

Picture 4. 3 holes for the hydraulic suspension cylinder

Blade angle could be adjusted also on the drive by adjusting hydraulic suspension cylinder.

4.4. **Pressure adjustment of the hydraulic suspension**

Factory adjustment of hydraulic suspension is 110 bar. Factory adjustment will be reached by tightening screw fully and opening it 6,5 round back.

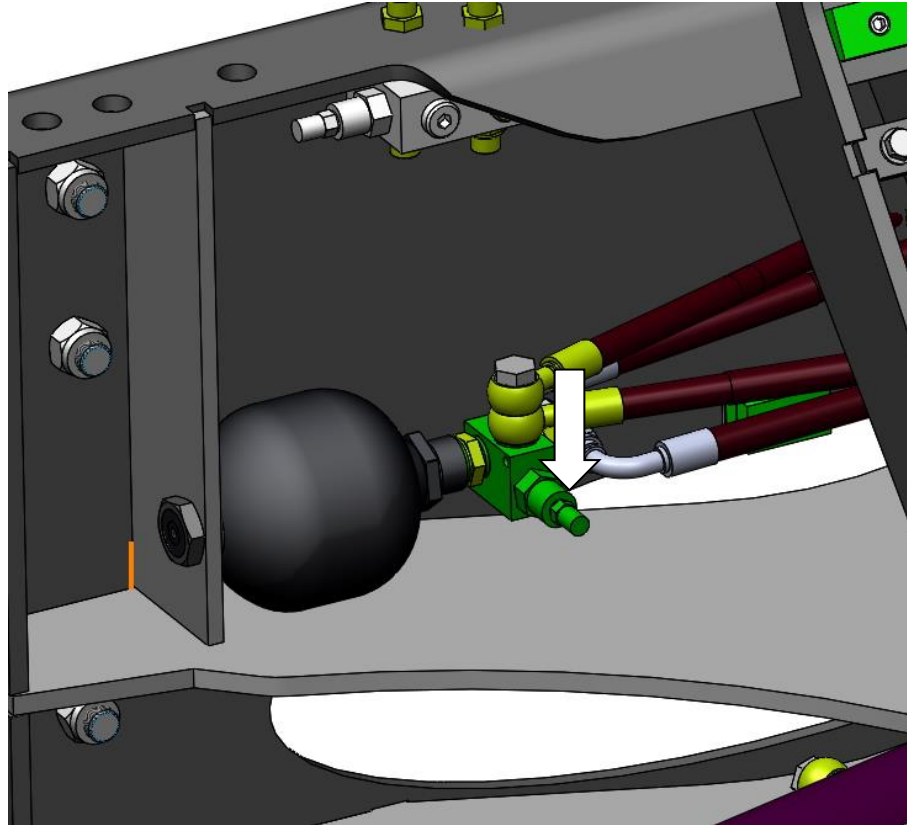

Picture 5. Pressure adjustment of the hydraulic suspension

Releasing the adjustment screw (Picture 5), tightness will go down and by tightening tightness go up.



OBSERVE:

Hydraulic suspension won't work if piston rod is fully out.



OBSERVE:

Too tight adjusted hydraulic suspension could cause danger situation both to the driver and equipment.

5. SERVICE

The most important thing to get maximum reliability is good service in time. Service costs are smaller compared to the repairing's costs. Below mentioned service includes all the lubrications and adjustments.

5.1. **Daily service**

- Check all the blades
- Check tightness of the fastening screws
- Test drive all the movements
- Clean the equipment in the end of the working day

5.2. **Weekly service**

- Lubricate all the nipples
- Check that there are no leakages

5.3. **Service after 500 working hours**

- Check all the pins and tightness
- Check tightness of the screws

5.4. **Annual service**

All above mentioned. Lubricate all the lubrication points always when leaving equipment to the storage.



NB!

When serving you should follow the service table also taking care of the previous services.



NB!

Tightness of the screws should be checked also after the first drive.



NB!

Lubricate also piston rods when leaving equipment to the storage place.

5.5. *Lubrication*

Lubricate nipples shown in the picture (Picture 8). Clean the top of the nipple before lubrication.

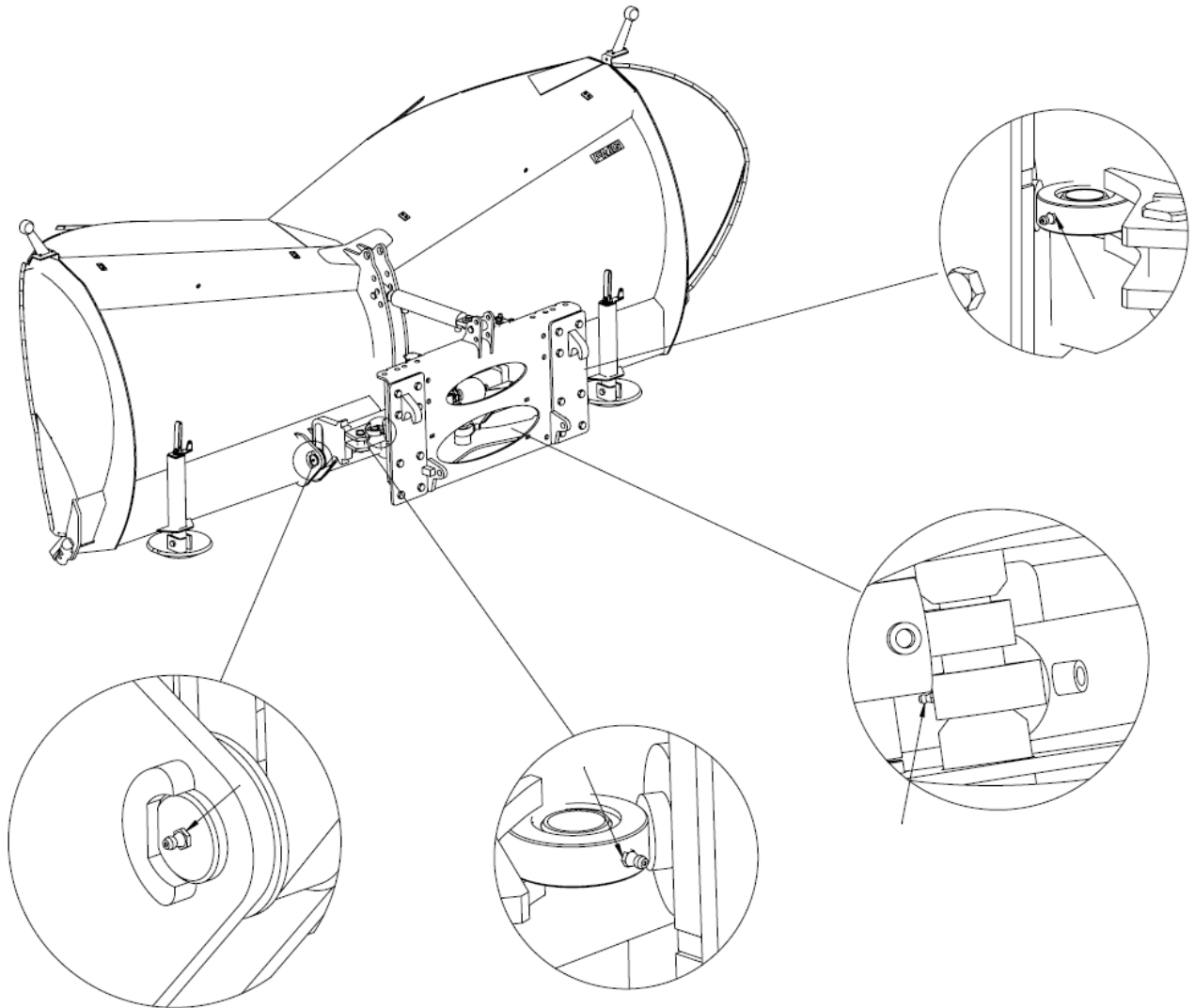

Picture 8. Lubrication

5.6. **Screws to be tighten**

Tighten all the screws after 10 hours' drive and after that between 500 working hours.

1. Tightening nut of the main pin in the center
2. Tightening screw of the support leg
3. All the blade screws
4. Tightening screws of the paving stone pin

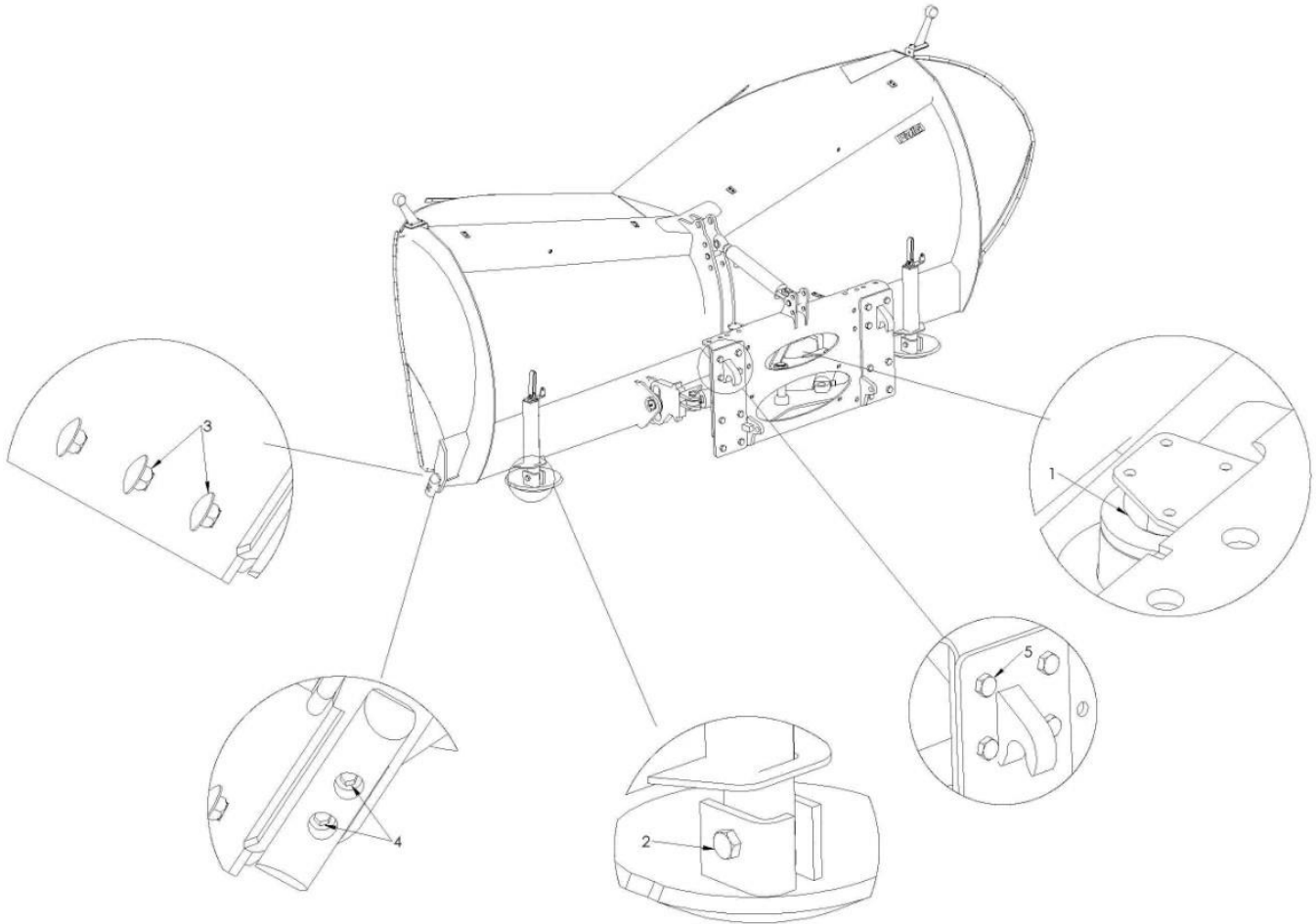

Picture 11. Screws to be tighten

6. ELECTRIC VALVE AND SIDE LIGHTS CONNECTION

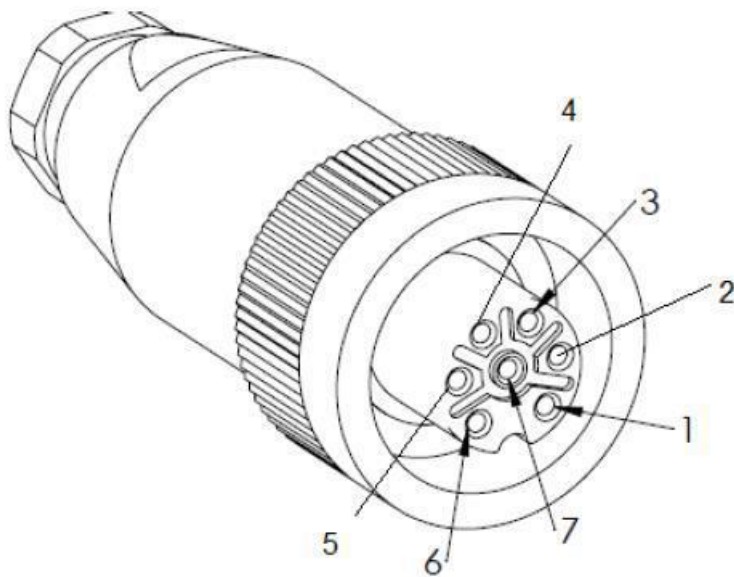
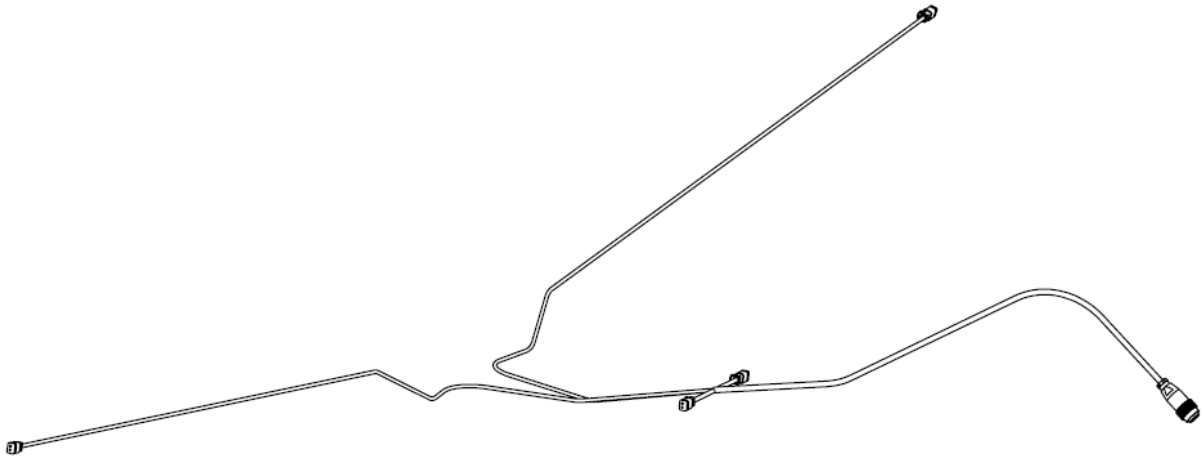

- 1.Side lights
- 4.Valve 1
- 5.Valve 2
- 6.Ground
- 7.Ground



LLP FARM MACHINERY GROUP OY

LEVYTIE 4
74510 IISALMI, FINLAND

PUH. +358 (0)20 1984 020
FAX +358 (0)20 1984 029

www.fmg.fi

