



**OPERATORS MANUAL**  
**AA245 – AA420**  
**AA300Z – AA360Z**  
**AA300L – AA360L**

ORIGINAL



ORIGINAL

### EY-VAATIMUSTENMUKAISUUSVAKUUTUS TUOTTEESTA

LLP Farm Machinery Group Oy vakuuttaa, että markkinoille saatettu kone täyttää direktiivin 2006/42/EY ja standardit SFS-EN ISO 12100 ja SFS-ISO 730:2020.

### FÖRSÄKRAN OM ÖVERENSSTÄMMELSE

LLP Farm Machinery Group Oy försäkrar härmed att tillförda maskin uppfyller maskindirektivet 2006/42/EY och standard SFS-EN ISO 12100 och SFS-ISO 730:2020.

### CERTIFICATE OF CONFORMITY FOR A PRODUCT

LLP Farm Machinery Group Oy certifies that the following machine, which has been brought into the market, conforms to directives 2006/42/EY and standards SFS-EN ISO 12100 and SFS-ISO 730:2020.

### SAMSVARSERKLÆRING FOR MASKIN

LLP Farm Machinery Group Oy bekrefter herved at følgende maskin, som er sendt ut på markedet, er i samsvar med direktivene 2006/42/EF, SFS-EN ISO 12100 og SFS-ISO 730:2020.

Tuote / Produkt / Product / Produkt: \_\_\_\_\_

Valmistusnumero / Tillverkningsnummer  
/ Serial number / Serienummer: \_\_\_\_\_

Teknisen tiedoston kokoaja / Teknisk  
dokumentation samlare / Technical file collector:

Valmistaja / Tillverkare / Manufacturer  
/ Produsent: LLP Farm Machinery Group Oy

Osoite / Adress / Address / Adresse: Levytie 4, FIN-74510 Iisalmi

Puhelin / Telefon / Telephone: +358 (0) 201 984 020

Paikka / Ort / Place / Sted: Iisalmi

Aika / Datum / Date / Dato: \_\_\_\_\_

Allekirjoitus / Underskrift / Signature  
/ Signatur:



Nimenselvennys / Namnförtydligande  
/ Clarification of signature  
/ Tydeliggjøring av signatur:

Jarkko Hyyrönmäki

## WARRANTY TERMS

All the products produced by LLP Farm Machinery Group Oy have twenty four (24) months warranty.

During the warranty period all the defects in material and in workmanship will be covered, in practical life FMG will replace defected parts with the new parts. Assembly, travelling expenses and freight of parts are not included in warranty.

Warranty will start in the beginning of usage of the product, if nothing else has been agreed.

Warranty is not covering damages due to misuse of product or use in the purposes where it has not been designed, lack of services or product has been modified without the permission of FMG.

Wearing of the normal usage is not covered by the warranty.

Losses in income, costs and loosen working hours caused by the defected part is not covered by the warranty.

Warranty repairs should be done by the FMG service dealer or service dealer appointed by the manufacturer.

In case the defects shown in reclamation is not valid or if case otherwise is not in the warranty area FMG has right to reject from the compensation.

Warranty reclamation should be done in written form by the FMG seller within one (1) month after notifying the defect.

In case of defect procedure is as follows:

- clarify the defect and defected area
- be prepared to deliver defected parts to the manufacturer
- contact FMG seller and make reclamation as follows:
  - type of the product and serial number
  - delivery date of the product (invoicing date)
  - date of the damage
  - description of the damage and pictures
  - description of the working conditions and the type of the base machine

## TO THE OPERATOR

The purpose of this manual is to provide support and instructions to areal plough users. Manual contains detailed instructions for driving, operating and maintaining the plough. Make sure that your new plough is always handled and maintained in the correct way in order to ensure reliability and economical operation for many years.

We recommend that you read the manual thoroughly. Follow the maintenance and service program carefully and include the daily maintenance in your normal routine. This is both you and your tractor interest.

Maintenance, repairs and adjustments which are not described in this Operator Manual require the use of special tools and exact technical data. In case of that kind need please contact your FMG seller or factory.

Use only genuine FMG spare parts for optimum performance from your tractor and plough. Spares will be sold through the FMG seller.

## TABLE OF CONTENTS

1.	SAFETY INSTRUCTIONS .....	6
2.	CONSTRUCTION .....	8
3.	TECHNICAL SPECIFICATIONS .....	10
4.	AREAL PLOUGH USE .....	11
4.1.	Using area.....	11
4.2.	Instructions.....	11
4.3.	Areal plough use:.....	12
4.4.	Pressure adjustment of the hydraulic suspension .....	14
4.5.	Hydraulic snow stopper .....	15
5.	SERVICE .....	16
5.1.	Daily service.....	16
5.2.	Weekly service.....	16
5.3.	Service after 500 working hours .....	16
5.4.	Annual service .....	16
5.5.	Lubrication .....	18
5.6.	Screws to be tighten .....	19
6.	ELECTRIC VALVE CABLES .....	20

# 1. SAFETY INSTRUCTIONS

This section summarizes the regulations that must always be followed when working with the plough. However, these regulations do not exempt the driver from statutory and other national regulations regarding traffic safety and occupational health and safety. Safety regulations that apply to different types of working sites and existing road traffic laws must always be observed. Tractor safety regulations accepted by the Finnish occupational safety and health administration have already been taken into account in the equipment design. The following section describes general safety precautions that must be observed regarding the use of the plough.



## IMPORTANT

**Do not use the plough for other purposes than it has been designed. Please read this manual carefully before using the implement.**



## IMPORTANT

**Before driving, make sure that all movements and functions work correctly.**



## DANGER

**When testing different movements of the plough make sure that there is no one close to tractor. Safety distance 5 meters.**



## IMPORTANT

**Advise other users on the use of the implement and ask them to read the manual.**



## DANGER

**Do not operate a faulty implement.**



## IMPORTANT

**Use the rotary beacon while working.**



**WARNING**

Observe the manufacturer's instructions while working.



**WARNING**

Pay attention to other road users.



**IMPORTANT**

Always lower the implement and stop the engine before leaving the cab.



**IMPORTANT**

Never service or clean an implement that is resting on the hydraulics. Use mechanical support. Always stop the engine for maintenance.



**WARNING**

Do not disconnect, connect or tighten pressurized hydraulic plugs.



**WARNING**

Do not inhale oil mist if a pressurized component becomes damaged. If oil comes into contact with the eyes, rinse with plenty of water and contact a doctor immediately.



**DANGER**

Pay attention to the direction of the plough in relation to the tractor. The plough attempts to steer the tractor.

## 2. CONSTRUCTION

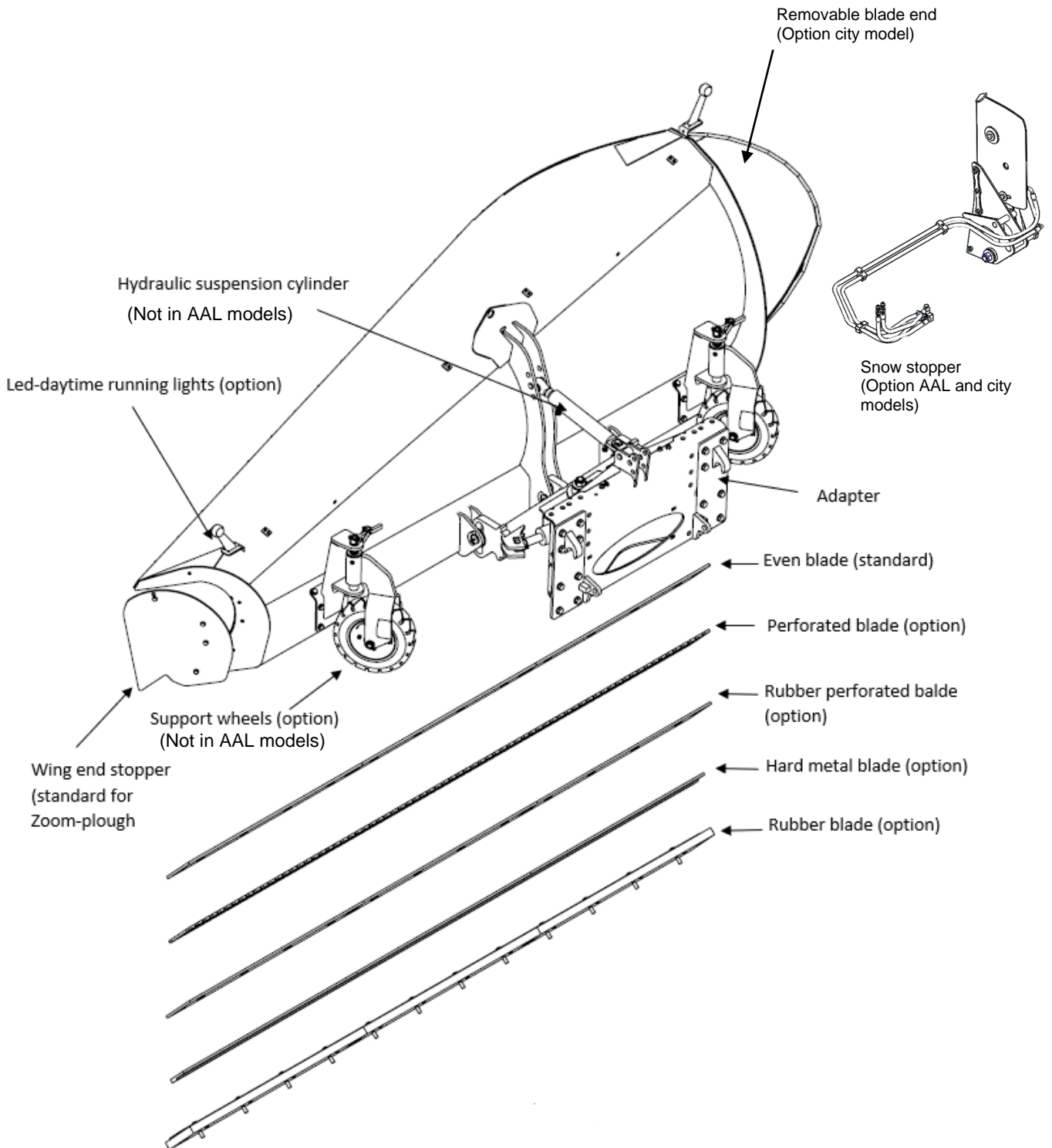

**Picture 1. Areal plough construction**



AA

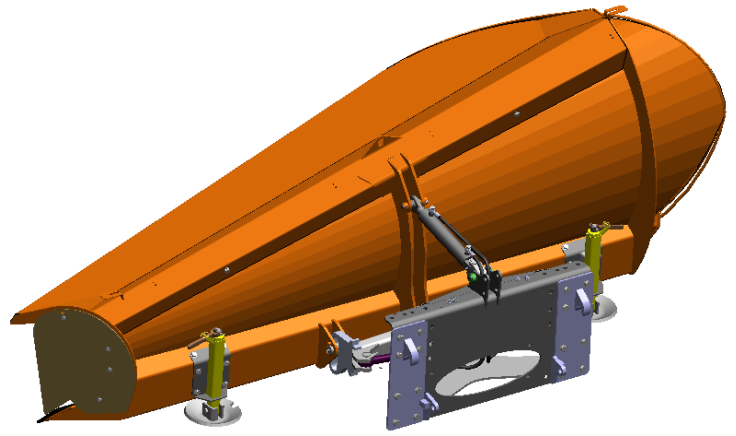
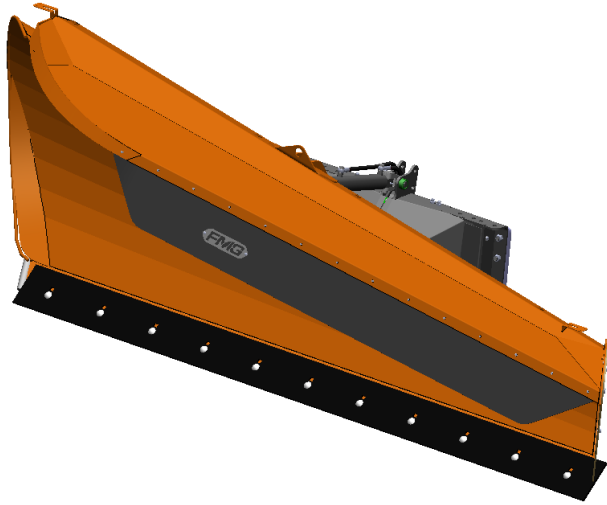

AAZ

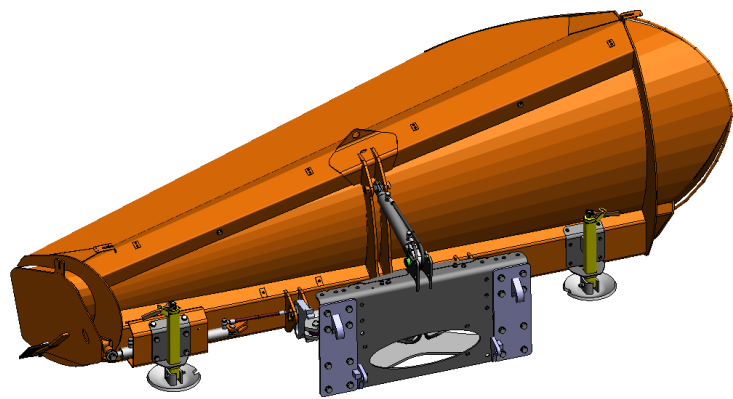
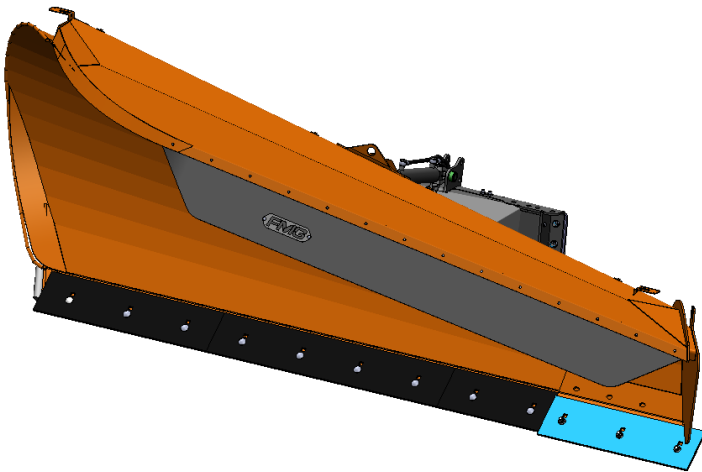

AAL

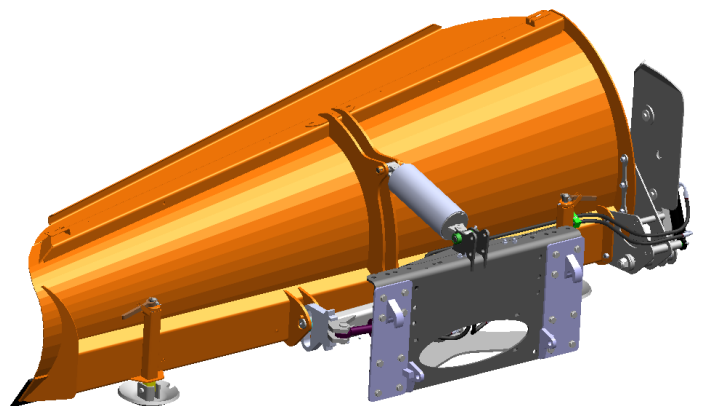
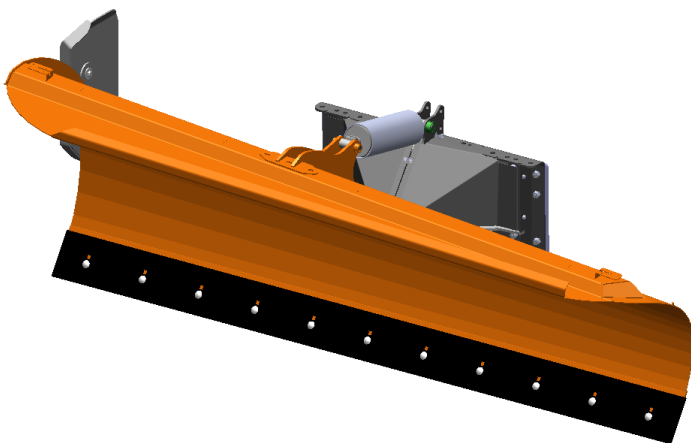

### 3. TECHNICAL SPECIFICATIONS

Model	Width (cm)	Working width (cm)	Weight (kg)	Wing angle
AA245	303	175 - 245	730	+45 / -41
AA275	334	195 - 275	770	+45 / -41
AA300	364	220 - 305	810	+45 / -41
AA330	395	240 - 335	850	+45 / -41
AA360	425	260 – 365	890	+45 / -41
AA390	456	280 – 395	960	+45 / -41
AA420	486	305 - 425	1010	+45 / -41
AA300Z	365	224 - 360	960	+45 / -41
AA330Z	395	244 - 385	1000	+45 / -41
AA360Z	427	264 - 420	1150	+45 / -41
AAL300	307	220 - 305	700	+45 / -41
AAL330	337	240 - 335	720	+45 / -41
AAL360	367	260 – 365	760	+45 / -41

Sound level is less than 70 dB (A).

## 4. AREAL PLOUGH USE

### 4.1. *Using area*

Areal plough is especially designed to the roads and light traffic roads. Areal plough is beneficial also when cleaning yards and terminals.

### 4.2. *Instructions*

Before use check that plough is engaged properly to the working machine and all the locking's are well done.

Test drive working machine and plough combination to ensure that all have been engaged well. If plough is new or it have been modified ensure that air has been eliminated from the system. Air in hydraulic system could cause unexpected movements.

When using areal plough ensure that your sight is clear to the ploughing area and there is not anyone in the dancer zone.

When disengage plough, put shields to the hydraulic hoses.

When disengage plough outside ensure that ground is balanced to help next engage. Wood blocks would be beneficial to balance the area.

If plough will stay longer period without usage, lubricate piston rods with CORRSHIELD VPCI-369 corrosion shield or with storage oil to avoid corrosion.

### 4.3. ***Areal plough use:***

Engage plough to the working machine that floating bar is in the mid position and plough is in the balanced position (Picture 2).

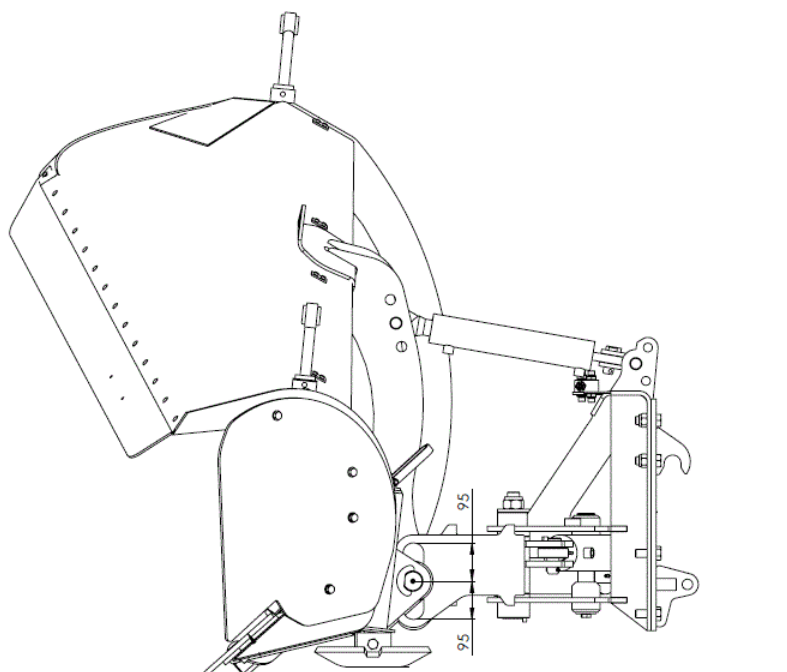

**Picture 2. Floating bar in the mid position**

In case the adapter is wrong change adapter and ensure that screws are tightened well.

Turn wing to the correct angle to get best possible ploughing result.



#### **IMPORTANT**

When plough is new take care that air from hydraulic system will be eliminated by turning cylinders against to the limit stoppers couple of the time.

Adjust support legs in order to blade will get correct height from the surface.

In case of front loader application beam support are recommended.

Working position of plough is correct when frame is in the upright position (Picture 3).

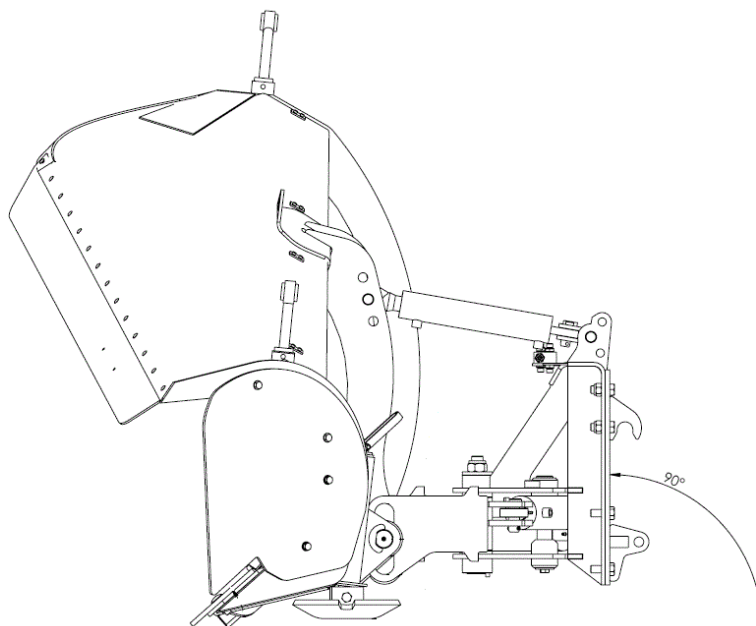

**Picture 3. Plough frame in the upright position**

In normal working position hydraulic suspension cylinder is in the minimum position. Blade angle is possible to adjust by moving suspension cylinder (Picture 4).

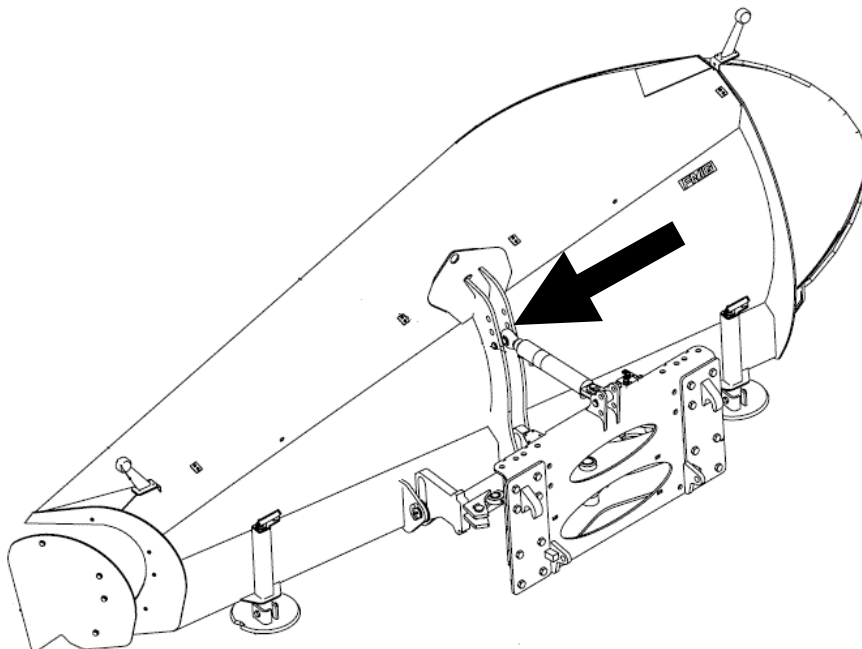

**Picture 4. 3 holes for the hydraulic suspension cylinder**

Blade angle could be adjusted also on the drive by adjusting hydraulic suspension cylinder.

#### 4.4. **Pressure adjustment of the hydraulic suspension**

Factory adjustment of hydraulic suspension is 110 bar. Factory adjustment will be reached by tightening screw fully and opening it 6,5 round back (Picture 5).

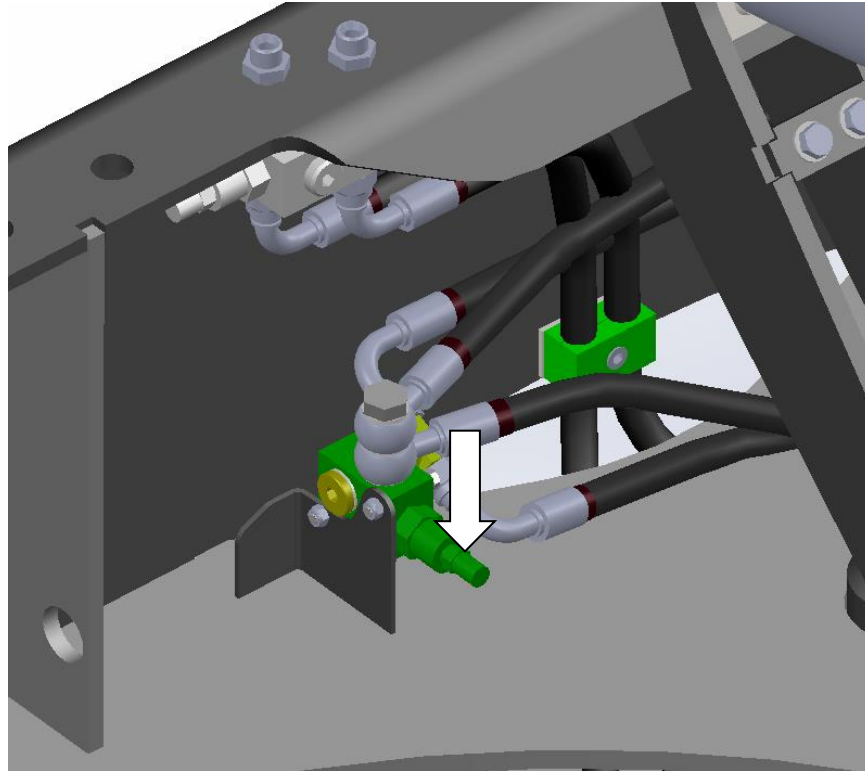

**Picture 5. Pressure adjustment of the hydraulic suspension**

Releasing the adjustment screw (Picture 5), tightness will go down and by tightening tightness go up



**OBSERVE:**

Hydraulic suspension won't work if piston rod is fully out.



**OBSERVE:**

Too tight adjusted hydraulic suspension could cause danger situation both to the driver and equipment.

#### 4.5. *Hydraulic snow stopper*

The optional snow stopper is designed to make it easier to keep the joints open.

Snow stopper is equipped with relief valve. When loosening the adjusting screw (Picture 6), stoppers holding force to ground degrees. Tightening the screw holding force increase.

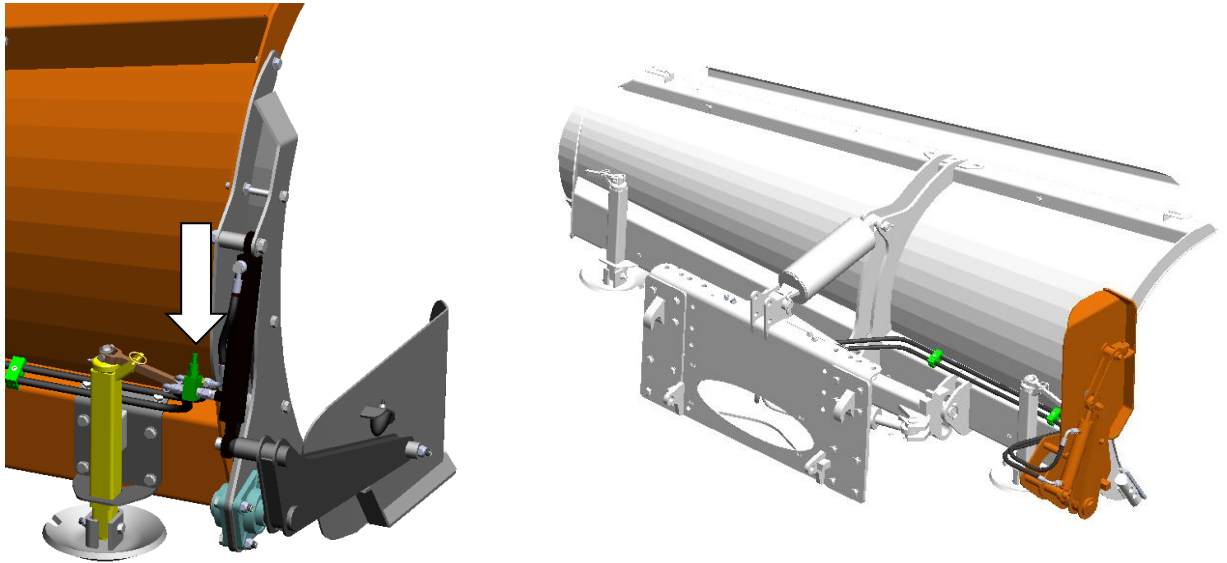

*Picture 6. Adjusting the relief valve*



**OBSERVE:**

**A snow stop that is set too stiff can endanger the driver and damage the implement.**

## 5. SERVICE

The most important thing to get maximum reliability is good service in time. Service costs are smaller compared to the repairing's costs. Below mentioned service includes all the lubrications and adjustments.

### 5.1. ***Daily service***

- Check all the blades
- Check tightness of the fastening screws
- Test drive all the movements
- Clean the equipment in the end of the working day

### 5.2. ***Weekly service***

- Lubricate all the nipples
- Check that there are no leakages

### 5.3. ***Service after 500 working hours***

- Check all the pins and tightness
- Check tightness of the screws

### 5.4. ***Annual service***

All above mentioned. Lubricate all the lubrication points always when leaving equipment to the storage.





**NB!**

When serving you should follow the service table also taking care of the previous services.



**NB!**

Tightness of the screws should be checked also after the first drive.



**NB!**

Lubricate also piston rods when leaving equipment to the storage place.

## 5.5. *Lubrication*

Lubricate nipples shown in the picture (Picture 10). Clean the top of the nipple before lubrication.

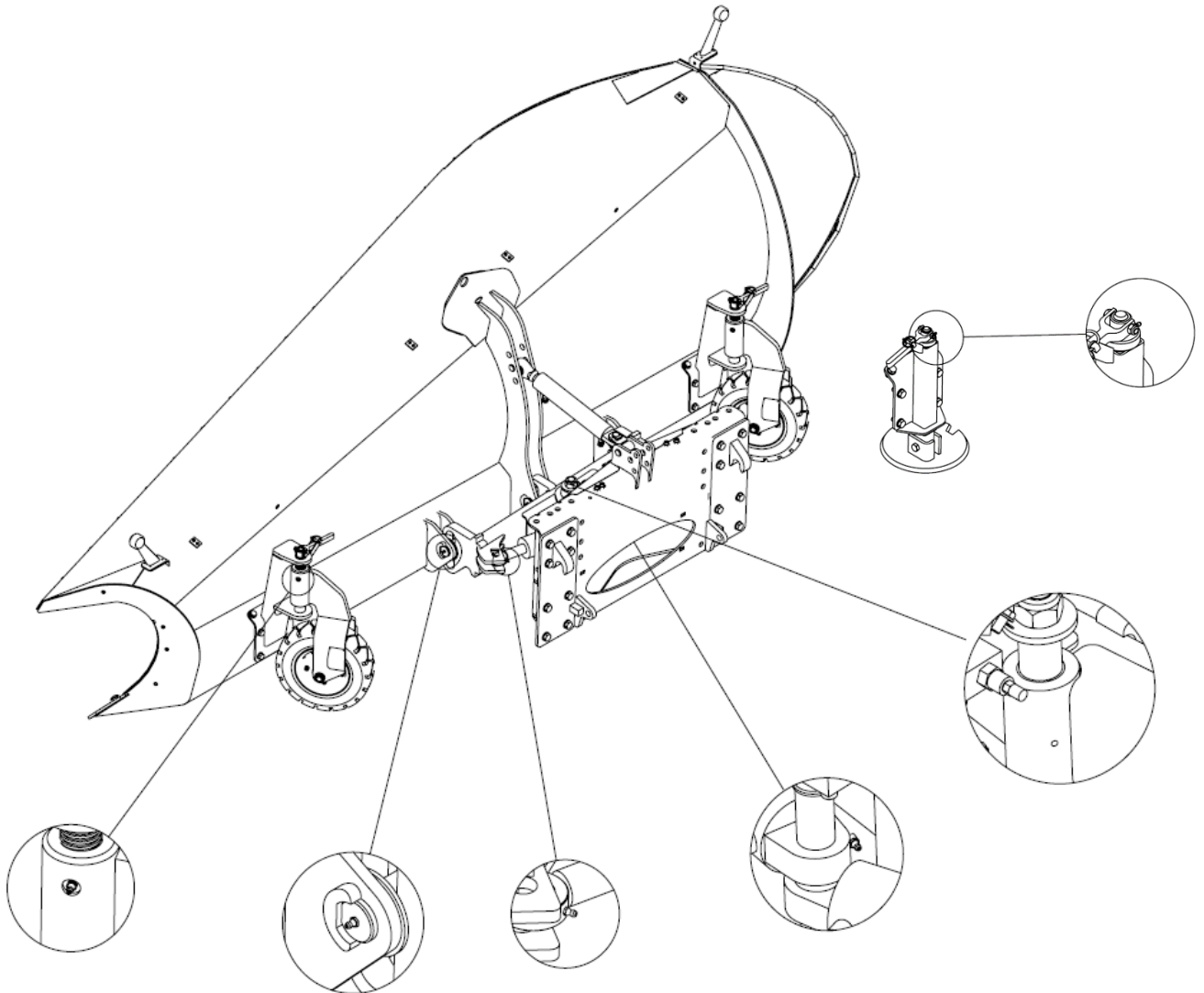

**Picture 10. Lubrication**

## 5.6. **Screws to be tighten**

Tighten all the screws after 10 hours' drive and after that between 500 working hours.

1. All the blade screws
2. Tightening screw of the support wheels
3. Tightening screws of the adapters.
4. Tightening nut of the main pin in the center
5. Tightening screws of the cylinders
6. Tightening screws of the paving stone pin
7. Tightening screws of support leg

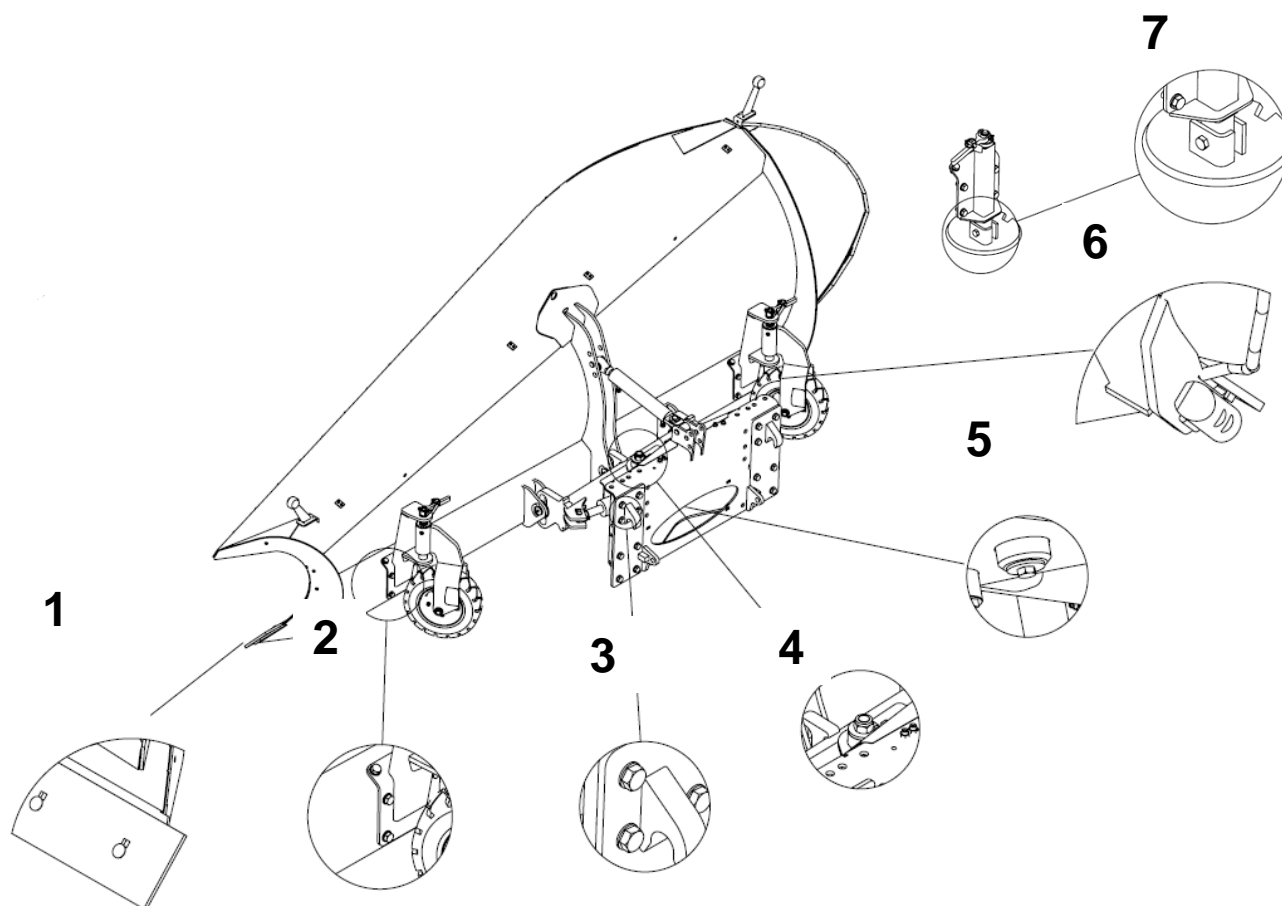

**Picture 11. Screws to be tighten**

## 6. ELECTRIC VALVE AND SIDE LIGHTS CONNECTION

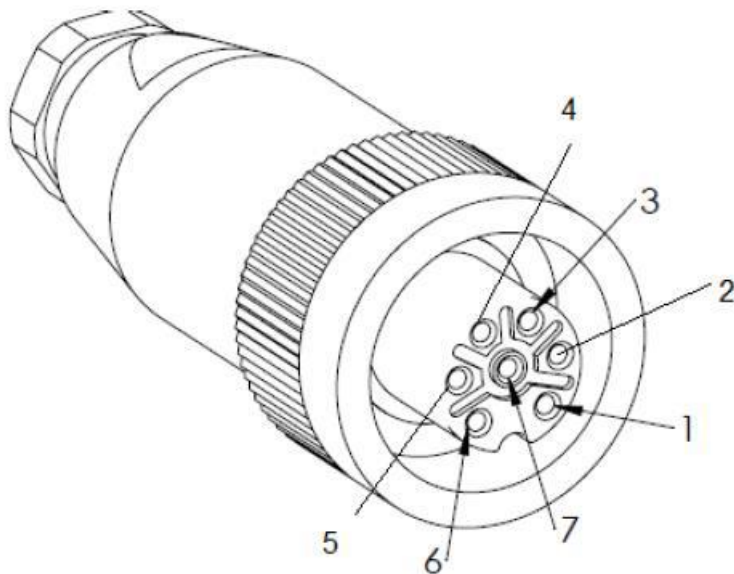
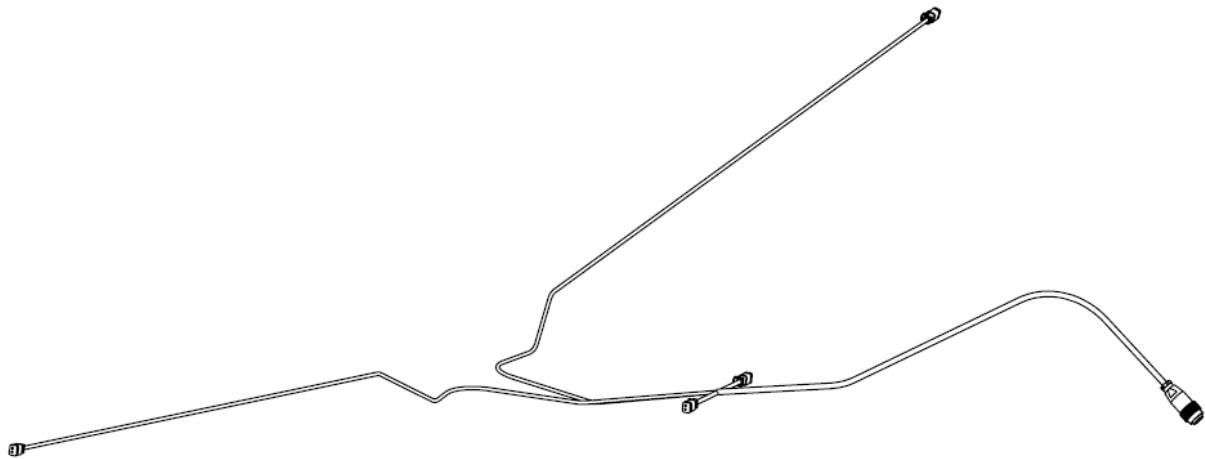

- 1.Side lights
- 4.Valve 1
- 5.Valve 2
- 6.Ground
- 7.Ground



**LLP FARM MACHINERY GROUP OY**

LEVYTIE 4  
74510 IISALMI, FINLAND

PUH. +358 (0)20 1984 020  
FAX +358 (0)20 1984 029

[www.fmg.fi](http://www.fmg.fi)

